

LGMG

AR18JE

ARTICULATING BOOM LIFT

- Li-battery powered provides quiet and zero emission.
- 260/350kg (573 /772 lbs) dual-capacity design.
- Oscillating, full-time floating axels allow the wheels to grip to the ground when driving on hard, uneven terrain.
- Integrated four-wheel-drive system provides strong power, smooth transmission, and 45% gradeability.
- Equipped with three steering modes and one-touch wheel alignment.
- Proportional lift and drive controls deliver smoother maneuvering, precise positioning and comfortable operation.



LGMG ELECTRIC - ARTICULATING BOOM LIFT

SPECIFICATIONS

MODELS	AR18JE (AR60JE)	
	Metric	Imperial
Measurements		
Work Height Max.	20.12m	66'
Platform Height Max.	18.12m	59'5"
Horizontal Outreach	10.9m	35'9"
Up and Over Height	7.7m	25'3"
Platform Length	1.83m	6'
Platform Width	0.76m	2'6"
A Stowed Length	8.42m	27'7"
Length-Transport (jib tucked)	6.42m	21'1"
B Overall Width	2.5m	8'2"
C Stowed Height	2.47m	8'1"
Height-Transport	3.07m	10'1"
D Wheelbase	2.51m	8'3"
E Ground Clearance	0.4m	1'4"

PRODUCTIVITY

Max. Platform Occupants	2(unrestricted) / 3(restricted)	
Platform Capacity	260/350kg	573/772 lbs
Turntable Rotation	360°	360°
Drive Speed-Stowed	5km/h	3.1mph
Drive Speed-Raised	0.8km/h	0.5mph
Gradeability	45%	45%
Max. Wind Speed	12.5m/s	28mph
Turning Radius-Inside	1.9m	6'3"
Turning Radius-Outside	3.9m	12'10"
Max.Slope	4°/4°	4°/4°
Tires Type	Foam-filled non-marking	
Tires Models	355/55D 625	

POWER

Power Source	80V 228Ah
--------------	-----------

HYDRAULIC SYSTEM

Hydraulic Oil Volume	90L	23.8gal
----------------------	-----	---------

WEIGHT

Machine Weight (CE/ANSI)	8,150kg	17,968 lbs
--------------------------	---------	------------

STANDARD FEATURES

Proportional control	Emergency stop device
Horn/Hour meter	Auto-leveling platform
Full-height drive	Anti-collision protection
Flashing beacons	Over tilt protection system
Cylinder bellows	Platform control cover
Oscillating axle	Overload sensing system
Platform tool box	Intelligent diagnostic system
Telematics connector	Foam-filled non-marking tires

OPTIONAL

Telematics	Solid tires
AC power to platform	Solid non-marking tires
Half-height mesh platform	Foam-filled tires
Auxiliary rail	Biodegradable hydraulic oil

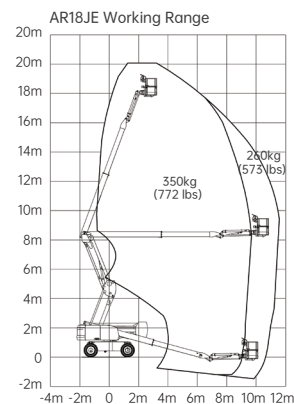
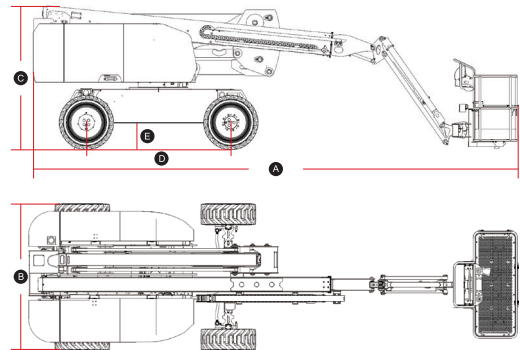

Please contact LGMG or a local dealer for more details.

LGMG reserves the right to change technical data without prior notice. All photos and pictures in this brochure are for promotional purposes only.

LINGONG HEAVY MACHINERY CO., LTD.

Address: No. 2676, Kejia Road, Jinan, Shandong, China
 Email: sales@lmgm.com.cn Tel: +86 531 6787 9283

LGMG Europe B.V.

Address: Donker Duyvisweg 301, 3316 BL Dordrecht, The Netherlands
 Email: sales@lmgmeurope.com Tel: +31 850 642 777

LGMG North America Inc.

Address: 4105 Live Oak Drive, Suite 100, The Colony, Texas 75056 United States
 Email: sales@lmgmna.com Tel: +1 833 288 5464

www.lmgmlifts.com



LGMG
 RELIABILITY IN ACTION